

## Installation guide

# LIPUMAX PPE GREASE TRAP

VERSION NO.	IMPLEMENTED BY	REVISION DATE	REASON
1	John Sordo	25 JULY 2023	New Grease Trap product Lipumax PPE
2	John Sordo	25 SEPTEMBER 2023	Amendment in image in section 4.1



# Contents

---

<b>1</b>	<b>GENERAL</b> .....	<b>3</b>
<b>2</b>	<b>SAFETY CONSIDERATIONS</b> .....	<b>3</b>
<b>3</b>	<b>SIZING</b> .....	<b>4</b>
<b>4</b>	<b>INSTALLATION &amp; SERVICEABILITY</b> .....	<b>6</b>
<b>5</b>	<b>CONTACT INFORMATION</b> .....	<b>12</b>
<b>6</b>	<b>APPENDIX</b> .....	<b>123</b>

## 1 GENERAL

---

When discharging tradewaste into the public sewer system, local water authority requirements must be adhered to.

The ACO Passavant Lipumax grease trap is designed for below ground installation only. Lipumax grease traps are designed to separate waste Fats, Oils and Grease (FOG) from commercial tradewaste in applications such as commercial kitchens. They are not anticipated for use in residential or for large industrial applications. In these instances, a specific tradewaste agreement exists with the local water authority.

## 2 SAFETY CONSIDERATIONS

---

All work in installing and maintaining this grease trap shall comply with requirements of the relevant authorities and Draft AS5215.

### 2.1 Site handling

Inspect the Lipumax upon delivery and prior to installation, check for damage that may have occurred during transportation or at the job site prior to installation.

Grease traps can be large. To avoid damage to the grease trap, ensure that correct equipment (e.g. forklift, crane or sling ropes) is available for proper unloading and manoeuvring on site. Use lifting provisions (shown below).



Note: 2000L and greater traps may require a 3 tonne excavator to dig the required depth.

### 2.2 Workplace Health and Safety (WHS)

- All safety instruction labels must be replaced if they become detached or illegible
- Installed devices (e.g. baffles, inlets, outlets etc.) are not load bearing. They must not be used as steps, footholds or resting places for cleaning equipment etc.
- Grease traps should not be installed where a danger to health is possible from the grease separator leaking, blocking or surcharging.
- Ensure the angle of excavation is suitable for the soil type.

### 3 SIZING

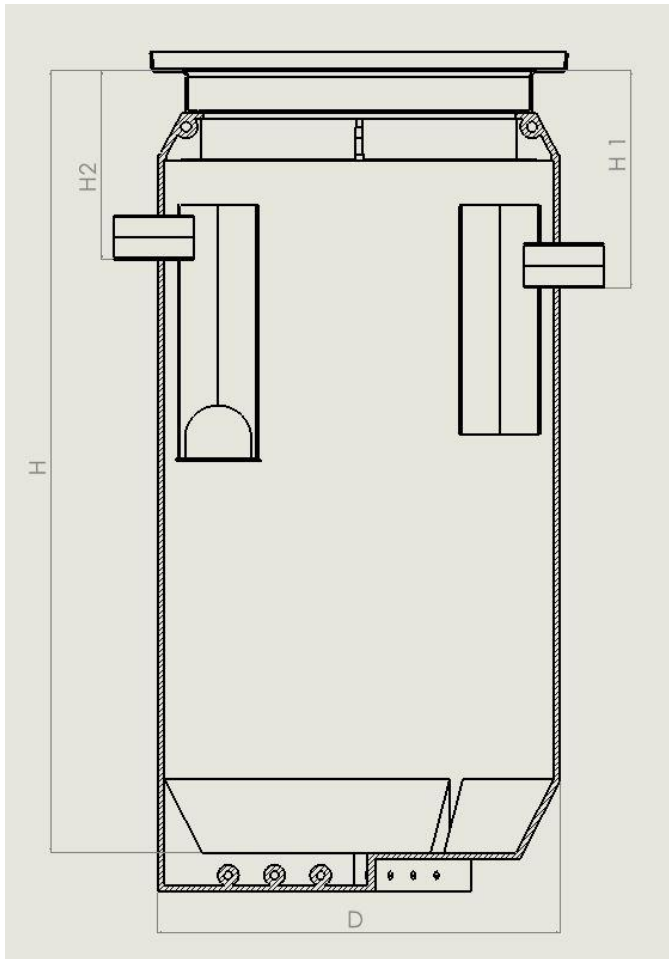

#### Grease trap range

Inlets, outlets and vents are (OD) 110mm dia.

Part No.	Description	Empty Weight (kg)	D Diameter of unit	H* Height of unit	H1* Invert of outlet to top	H2* Invert of inlet to top
143267	Lipumax PPE 1000L	116	1000	1944	540	470
143268	Lipumax PPE 1500L	143	1400	1645	555	485
143269	Lipumax PPE 2000L	207	1400	2117	725	655
143270	Lipumax PPE 3000L	287	1950	1702	590	520
143271	Lipumax PPE 4000L	352	1950	2095	550	480
143272	Lipumax PPE 5000L	467	1950	2397	580	510

#### Grease trap accessories

Part No.	Description	Weight (kg)
142350	Riser tube (short)	22
142970	Riser tube (long)	48

Each Lipumax trap requires a gas and water tight access cover (complaint to AS 3996) to close the system and offer access for maintenance purposes. A range of Class B and Class D covers and assemblies are available.

### Cover and collar

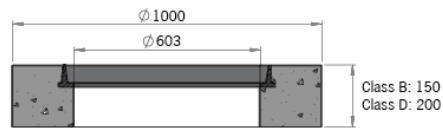

### Cover, collar and riser tube

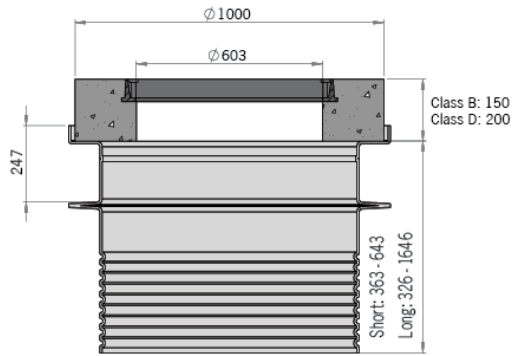

### Cover, collar, riser tube and load distribution plate

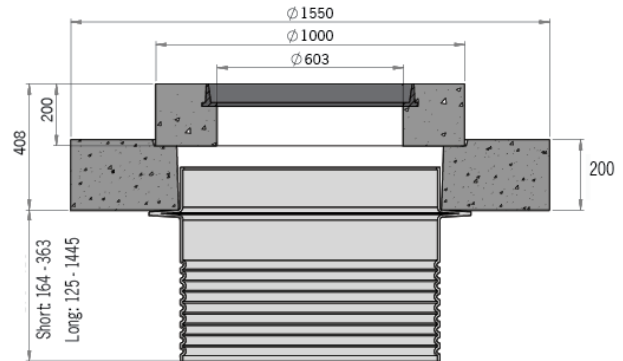

**Note:** All dimensions are in mm.

## Cover assemblies

Cover Type	Cover & Collar Part No. Weight (kg)		Cover, collar & riser tube				Cover, collar, riser tube & load distribution plate			
			Short		Long		Short		Long	
			Part No.	Weight (kg)	Part No.	Weight (kg)	Part No.	Weight (kg)	Part No.	Weight (kg)
Rhinocast Class B	142120	215	142781	237	142951	262	142299	1121	142953	1146
Rhinocast Class D	142099	366	142782	388	142952	413				

## 4 INSTALLATION & MAINTENANCE

---

The Lipumax grease trap must be installed by a qualified plumber in compliance with local water authority regulations, Safe Work Australia, national plumbing standards and all other codes of practice. Prior to installation, ensure that the local water authority approves each installation.

The cover assembly selection will determine the overall installation depth. When installed, the tops of the cover and collar assembly should be flush with the finished surface level.

### 4.1 Installation steps

1. Check all dimensions carefully before installation. Excavate to the required depth, allowing for the trap depth (as outlined in section 3) and an additional 100mm, and at least 300mm on either side. The width of excavation should provide of a working area for the compactor.
2. Place stabilised bedding sand or concrete in the base of the hole and compact so it is level and free of rocks or other unsuitable materials.
3. Connect the required lifting apparatus to the grease trap. Lower the grease trap into the excavation and align the inlet, outlet and ventilation pipes to required positions. Place 200mm stabilised bedding sand or concrete around the trap and compact. The grease trap should be filled with water and backfilled with compacted sand and gravel or soil in 300mm sections. Ensure backfill is free of rocks, or other unsuitable materials.
4. Connect inlet, outlet, I.O/TWSP and vent pipes. Two vent connections are available to suit on-site requirements.
5. Position and install the selected cover and collar assembly.

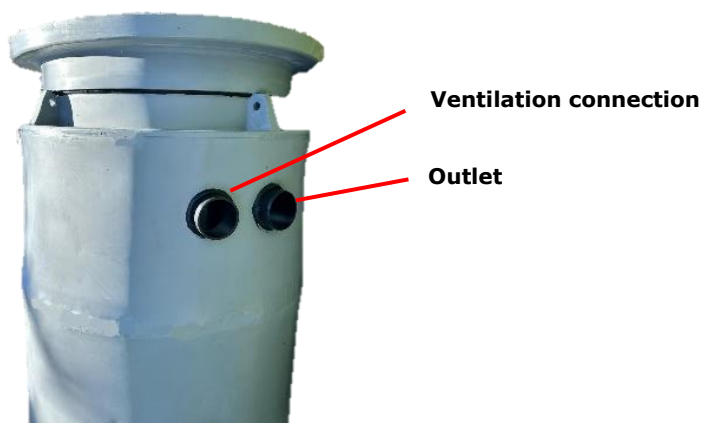

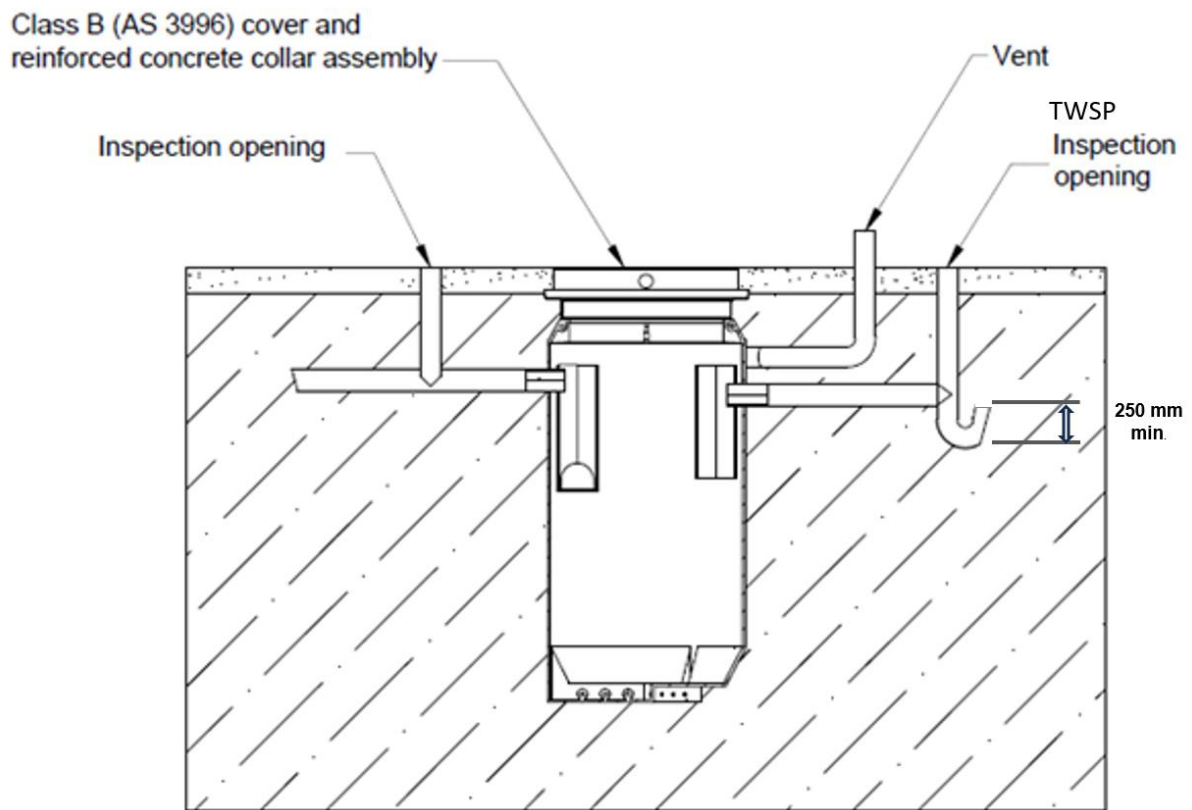

\*I.O – Inspection opening/ TWSP – Trade Waste Sampling Point

## 4.2 Connecting pipes

Lipumax grease traps can be used in conjunction with a number of different pipe materials. Connecting pipes and pipe materials should be installed in accordance with AS/NZS 3500 and local plumbing codes.

Note: Check manufacturers' approvals for use in ground slab applications, prior to use. Couplings are not supplied by ACO.

### HDPE pipe

- HDPE connector (left)
- Flexible coupling (middle)
- Flex seal shielded coupling (right)



### **PVC pipe**

- Flexible coupling (left)
- Flex seal shielded coupling (middle)
- PVC slip coupling (right)



### **4.3 Installation drawings**

Following are some typical installation details. For additional installation details and downloadable installation details, visit <https://www.acopassavant.com.au/product-support/downloads/#Install>



### Class B (AS 3996) with access cover and reinforced concrete collar

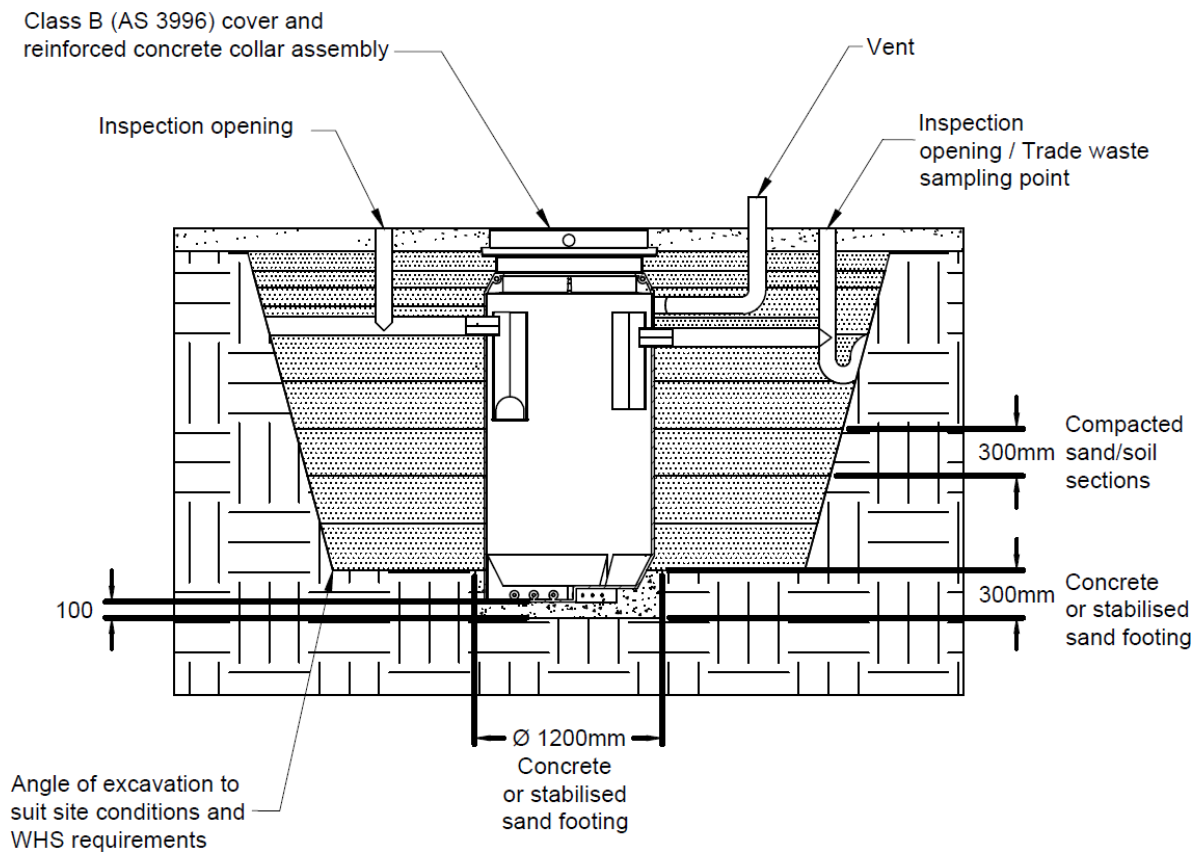

## Class D (AS 3996) with concrete collar, load distribution plate and riser tube

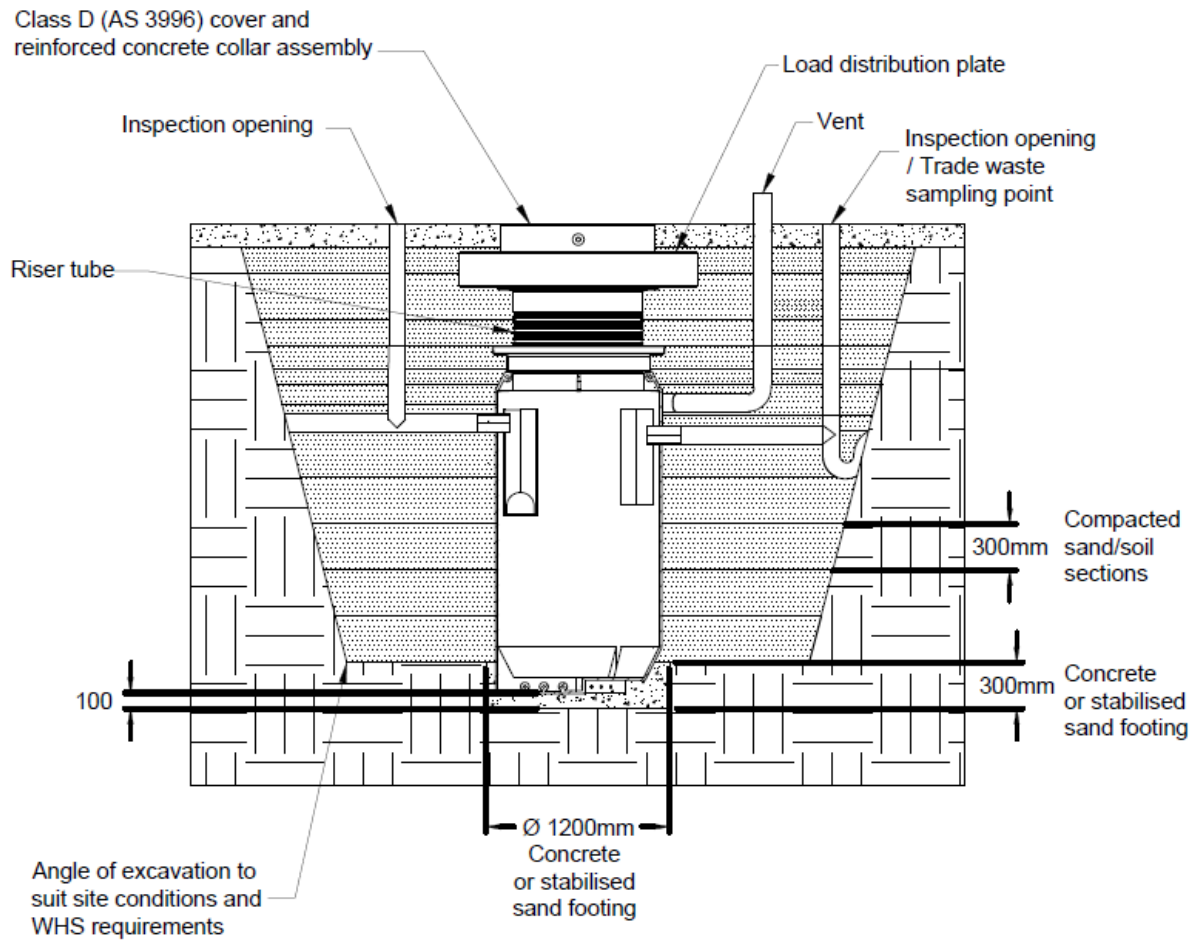

### Riser

Prior to installation the rebate must be cut to off the top of the riser tube (along the dotted line shown below) using the groove provided, as per the diagrams below. To ensure water tightness, apply acid free grease to the seal and collar seating and before installing the concrete collar and cover, ensure the riser tube has been backfilled.

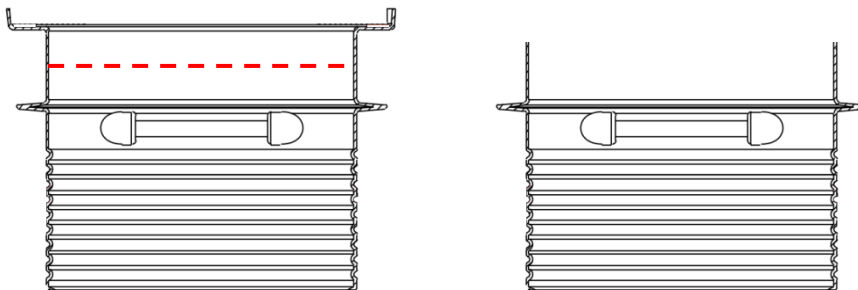

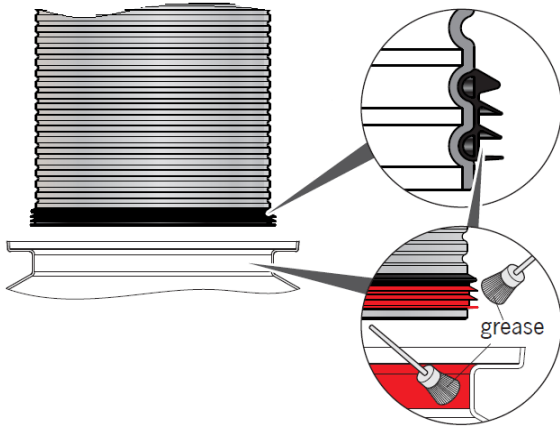

1. Prepare riser by cutting it to the required height.
2. Lubricate the riser tube, sealing ring and internal face of the separator
3. Slide the sealing ring onto the riser tube
4. Push the riser tube into the installed separator

### Class D (AS 3996) with concrete collar to suit engineered slab detail

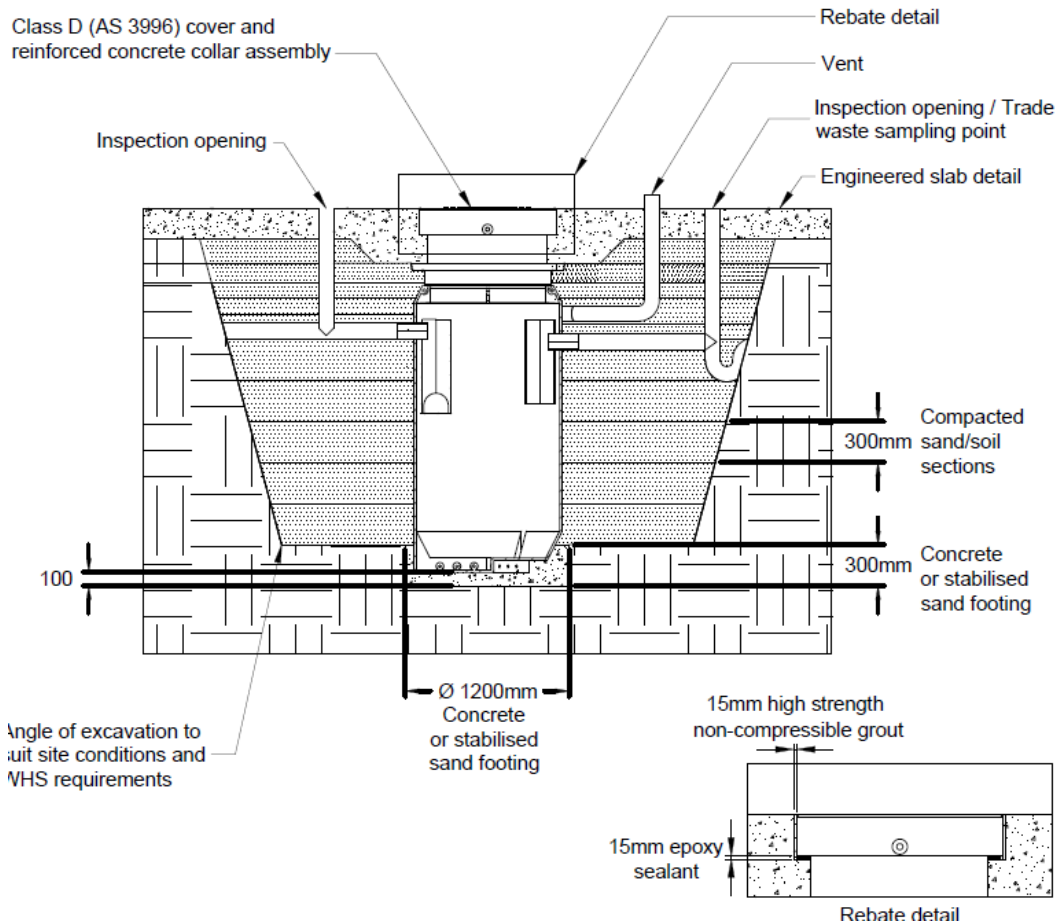

#### 4.4 Frequency of servicing

A regular cleaning and disposal procedure is critical for the ongoing efficiency of the grease trap.

The service frequency is stipulated in the maintenance agreement with the local water authority and will depend on the volume of FOG that is generated in a specified time. In the absence of this information, ACO recommends at least an annual service of the grease trap

The maintenance is recommended to be undertaken by a specialist waste management contractor. A licenced plumber is to empty and service the grease trap, check that the connecting pipework is free from obstruction and ensure the trap is structurally sound.

#### 4.5 Design life

ACO's Lipumax grease traps are manufactured from polyethylene, which is designed to exceed a design life of 5 years.

This does not exclude extenuating circumstances outside of ACO's control where performance may be compromised e.g. poor maintenance, poor installation/soil mechanics, excessive wheel loads etc...

## 5 CONTACT INFORMATION

---

For queries, servicing assistance and spare parts, contact ACO.

**ACO Pty Ltd**

134-140 Old Bathurst Road

Emu Plains

NSW 2750

Australia

e: [sales@acoaus.com.au](mailto:sales@acoaus.com.au)

p: +61 2 4747 4000

## 6. APPENDIX

---

For queries, servicing assistance and spare parts, contact ACO.

### WATER CORPORATION (supplement)

- Refer to drawings HX33-10-10 & HX33-10-30 for precise construction requirements for Trade Waste Sampling Point (TWSP).
- Only camlock fittings are to be used for pump out line and no fixed suction is to be installed.
- A baffle cap is required to be installed as to manufacturer's instructions on the outlet baffle to prevent surcharge. Riser tubes are optional. Refer to table below for ordering information.
- A hose tap fitted with a backflow prevention device must be located within 5 metres of the grease trap for cleaning purposes (as per AS/NZS 3500).
- For grease trap installation include adequate backflow prevention guidelines, refer to Water Corporation *Grease Arrestors Installation Guidelines (Information Sheet 23B)*.
- The grease trap model and size can be identified on the trap and an external label:

### Lipumax accessories table

Part No.	Description	Weight (kg)
142350	Riser tube (short)	22.0
142970	Riser tube (long)	48.0
142105	Baffle cap to suit 110 Ø inlet/outlet	0.1
142106	Baffle cap to suit 160 Ø inlet/outlet	0.1

### SYDNEY WATER (supplement)

- Grease traps are to be cleaned out at a minimum interval of 6 months, depending on usage.

### SA Water (supplement)

- A baffle cap is required on the outlet baffle to prevent surcharge.